

Features

Heavy duty frame and drum construction

Cast aluminum stationary spring loaded nozzles

Sizes from 6' to 9' diameter with numerous CFM options

Simple filter media replacement with various styles for your particular application

Options

Outlets: Single or double

Plenum wall: Single section or split horizontally

Cage construction: Solid ring cage or split horizontally.
Steel or aluminum

Stationary nozzles: Mounted on either side of drum or at

Available Services

- System Integration
- Industrial Ventilation
- Material Handling
- Power & Controls
- Manufacturing

For more information on any of our products or services - please visit us on the Web at:

www.steimelmetalfab.com

AUTOMATIC SELF CLEANING VACU DRUM FILTER

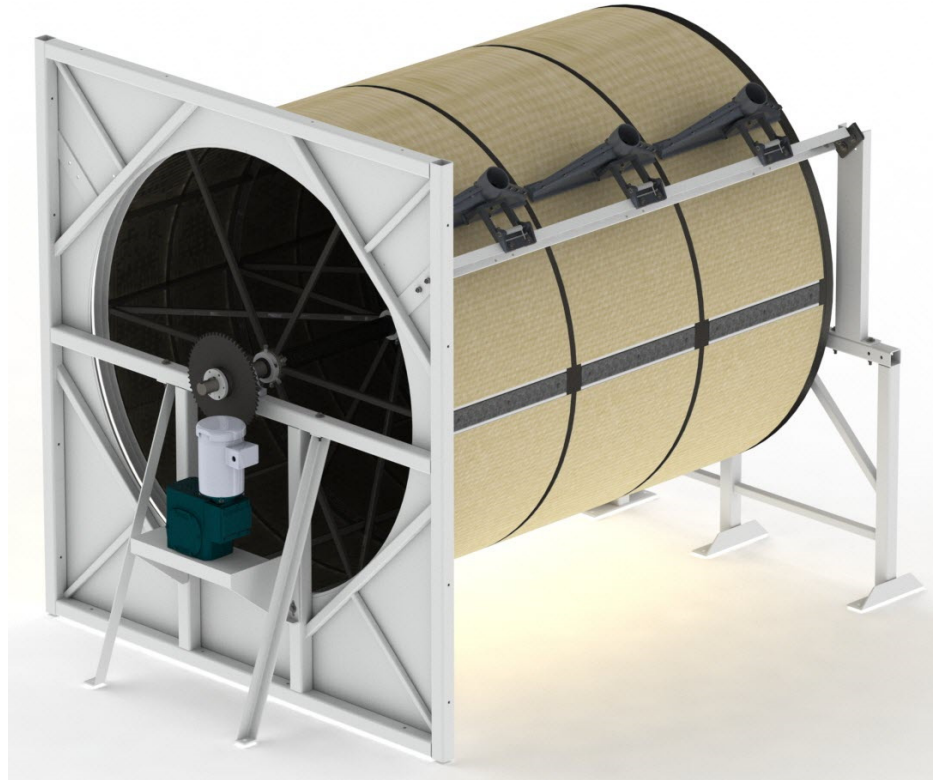

The rotating Vacu-Drum Filter utilizes stationary nozzles and heavy duty drive to produce a self cleaning automatic filter with years of proven use in the industry. Drum cages are constructed of rolled angle iron with 1"x1" square tubing spokes. Heavy duty pillow block bearing on both ends of shaft. Heavy duty 3" OD tubing shaft. Drum is rotated by a heavy-duty chain and sprocket connected to a gear reducer. Filter media is sewn into a one piece blanket with a zipper and is held in place with holding bands between each nozzle.

- Heavy-duty drive with sprockets and chains, equipped with torque limiter
- Expanded metal cages with approximately 80% free air area
- Simple filter media installation
- Unique sealing device
- Minimum number of moving parts
- Spring loaded cast aluminum nozzle and bracket
- Completely automatic

SME
STEIMEL METAL FAB, LLC.

Hamilton, OH (513) 616-8647

Steimelmetalfab.com

AUTOMATIC SELF CLEANING VACU DRUM FILTER

MODEL	MEDIA AREA SQ. FT.	MEDIA FACE VELOCITY		
		50 FPM	100 FPM	150 FPM
6-3	117	5,850	11,700	17,550
6-4	157	7,850	15,700	23,550
6-5	197	9,800	19,600	29,400
6-6	237	11,750	23,500	35,250

7-3	137	6,850	13,700	20,550
7-4	183	9,150	18,300	27,450
7-5	229	11,450	22,900	34,350
7-6	274	13,700	27,400	41,100
7-7	319	15,950	31,900	47,850

8-3	157	7,850	15,700	23,550
8-4	209	10,450	20,900	31,350
8-5	261	13,050	26,100	39,150
8-6	314	15,700	31,400	47,100
8-7	366	18,300	36,600	54,900
8-8	418	20,900	41,800	62,700

MODEL	MEDIA AREA SQ. FT.	MEDIA FACE VELOCITY		
		50 FPM	100 FPM	150 FPM
9-4	235	11,700	23,500	35,300
9-5	294	14,700	29,400	44,100
9-6	353	17,650	35,300	52,950
9-7	412	20,600	41,200	61,800
9-8	470	23,500	47,000	70,500
9-9	529	26,450	52,900	79,350

10-5	327	16,350	32,700	49,050
10-6	393	19,650	39,300	58,950
10-7	459	22,950	45,900	68,850
10-8	525	26,250	52,500	78,750
10-9	591	29,400	58,800	88,200

Model number determined by cage diameter (6' thru 10') & number of cages.

Standard sizes are listed—special sizes available upon request.

DRUM DIA.	A HEIGHT	B WIDTH
6'	7'-6"	7'-0"
7'	8'-6"	8'-0"
8'	9'-6"	9'-0"
9'	10'-6"	10'-0"
10'	11'-6"	11'-0"

NO. OF CAGES	E LENGTH
2	6'-4"
3	8'-7"
4	10'-10"
5	13'-1"
6	15'-4"
7	17'-8"
8	19'-10"
9	22'-1"

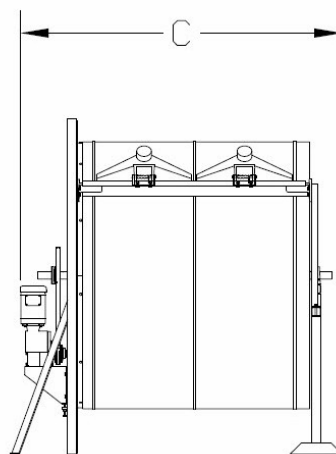
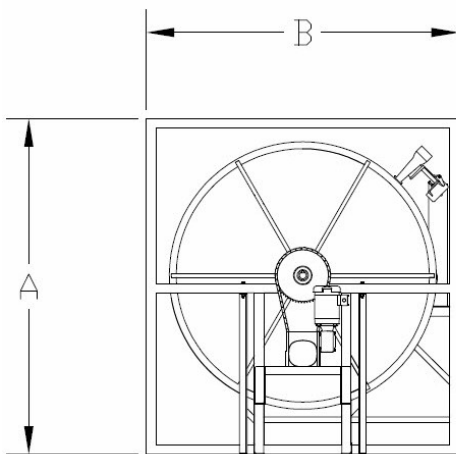

SME
STEIMEL METAL FAB, LLC.

Hamilton, OH (513) 616-8647
Steimelmetalfab.com